

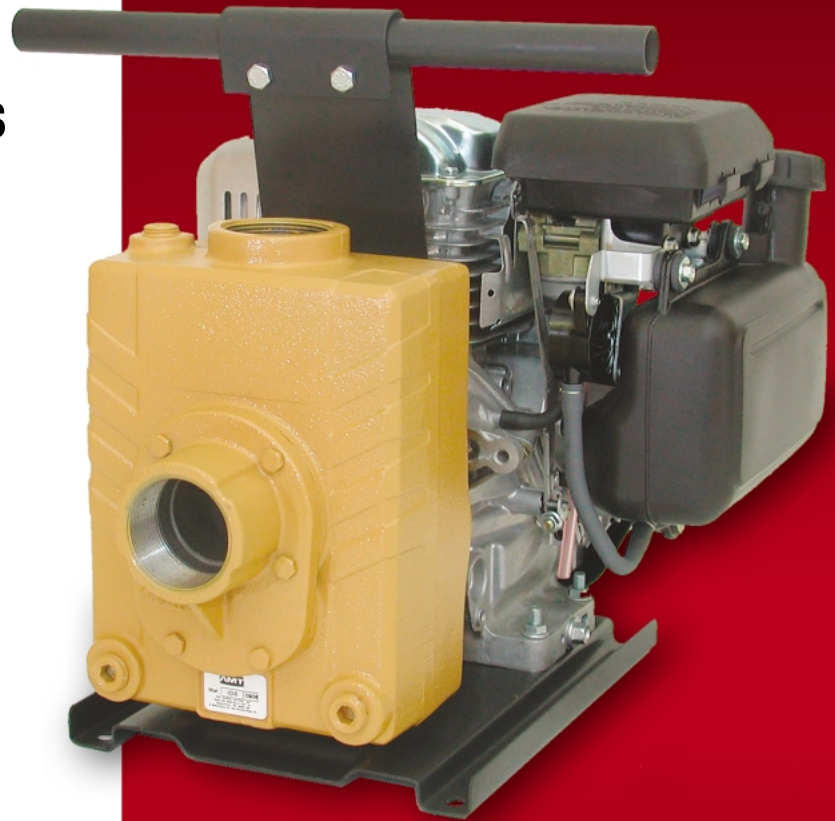

**NEW  
BUILT-IN  
CHECK VALVE  
ON CAST IRON  
PUMPS**

## 2" Engine Driven AG/Dewatering Pumps

- **Cast Iron or Thermoplastic Construction**
- **Buna or Viton® Mechanical Seal**  
- See Spec Chart for Specific Model
- **Optional Seals Available**  
(See Price Sheet for Specific Model Options)
- **2" NPT Port Sizes**
- **Self-Priming up to 20 ft.**
- **Semi-Open, Clog Resistant Impellers**
- **Engine Options: Honda and Briggs & Stratton**
- **Pumps Include Carrying Handle**
- **Heavy Duty Steel Base on Cast Iron Models**
- **Built in Flapper/Check Valve**



**2" Dewatering Pump (Cast Iron)**



**2" Thermoplastic Pump**

The AMT line of Engine Driven Dewatering pumps offers economy, durability, portability and performance all in one neat package. Ideal for general purpose dewatering, irrigation, spraying, washdown and agricultural applications. Cast Iron pumps feature dual volute design that reduces radial load on engine. Built in flapper/check valves enable constant self-priming to 20 ft. Pump construction materials range from Cast Iron to corrosion resistant thermoplastic components featuring removable/replaceable volutes, impellers and wearplates. Pumps are available with Briggs & Stratton or Honda engines. Viton®, EPDM and Silicon Carbide mechanical seal options are available on specific models.

AMT Engine Driven Dewatering pumps are reliable, cost effective and low maintenance. Many are readily available "Off-the-Shelf" for fast 24 hour shipment. For use with non-flammable liquids which are compatible with pump component materials.

Viton® is a registered trademark of E.I. DuPont

## INDUSTRIAL DUTY

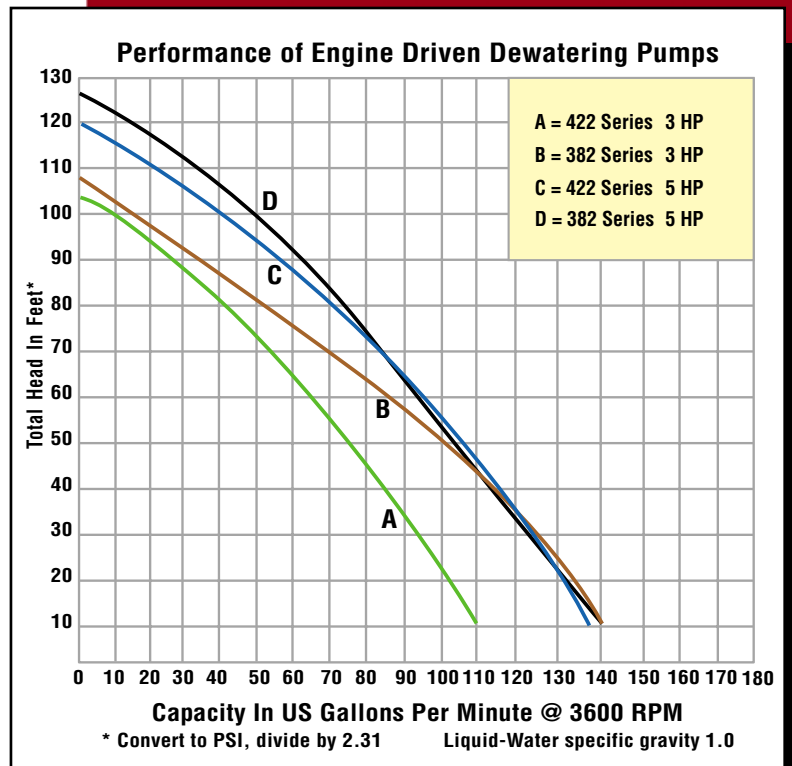

## 2" Cast Iron AG/Dewatering Pumps

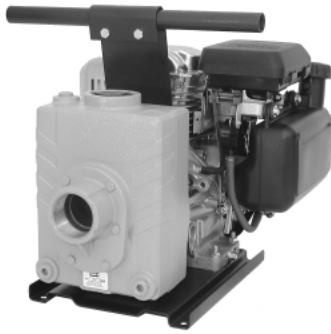

Model#	Curve	Ports	Driver	Construction	Seal	Ship Wt.	Run Time	Tank size
4222-95	A	2" NPT	B&S 525	Cast Iron	Buna	65	180 min.	3 qt.
4222-V5	A	2" NPT	B&S 525	Cast Iron	Viton®	65	180 min.	3 qt.
4223-95	C	2" NPT	B&S CP650	Cast Iron	Buna	76	90 min.	3 qt.
4223-V5	C	2" NPT	B&S CP650	Cast Iron	Viton®	76	90 min.	3 qt.
4225-95	C	2" NPT	HONDA GC160	Cast Iron	Buna	70	60 min.	1.8 qt.
4225-V5	C	2" NPT	HONDA GC160	Cast Iron	Viton®	70	60 min.	1.8 qt.

Maximum Solids Handling Capability: 3/8" Diameter

### Standard Features

- ▶ Two NPT Pipe Nipples
- ▶ Buna-N Mechanical Seal
- ▶ Optional Viton® or Silicon Carbide Mechanical Seals
- ▶ Built in flapper/check valve
- ▶ Fiber Gasket Casing Seal
- ▶ Self-primes to 20 ft.
- ▶ Semi-Open, Clog Resistant Impeller
- ▶ Stainless Steel Shaft Sleeve
- ▶ Maximum Temperature 180° F
- ▶ Maximum Working Pressure 60 PSI
- ▶ Delivers up to 52 PSI and 8400 GPH (Maximum)
- ▶ Dual Volute Design

## 2" Thermoplastic AG/Dewatering Pumps

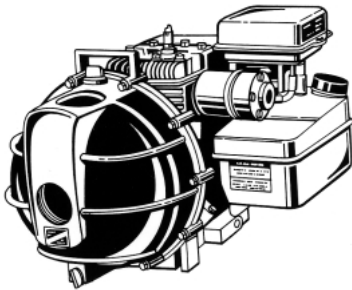

Model#	Curve	Ports	Driver	Construction	Seal	Ship Wt.	Run Time	Tank size
3824-99	B	2" NPT	B&S 525	Polypropylene	Buna	38	180 min.	3 qt.
3825-99	D	2" NPT	B&S CP550	Polypropylene	Buna	43	90 min.	3 qt.
382A-99	D	2" NPT	HONDA GC160	Polypropylene	Buna	45	60 min.	1.8 qt.

Maximum Solids Handling Capability: 7/16" Diameter

### Standard Features

- ▶ Two NPT Pipe Nipples
- ▶ Buna-N Mechanical Seal and Flapper Valve
- ▶ Optimal EPDM Mechanical Seal Available 1000-999-E0
- ▶ O-Ring Casing Seal
- ▶ Self-primes to 20 ft. with Built in Check Valve
- ▶ Replaceable Volute
- ▶ Maximum Temperature 130° F
- ▶ Maximum Working Pressure 60 PSI
- ▶ Delivers up to 54 PSI and 8460 GPH (Maximum)

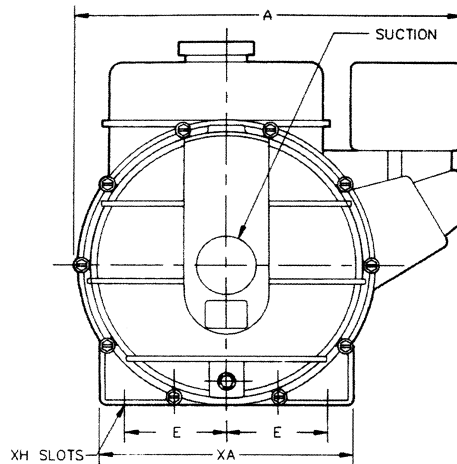
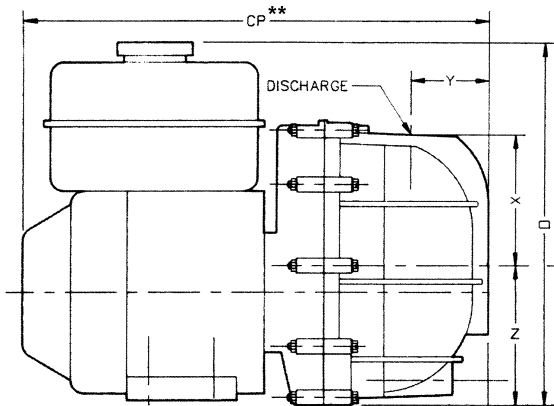

MODEL#	HP CLASS++	A	XA	CP**	E	XH	O	X	Y	Z
3824-99	3.5	16.5	7.3	17.8	3.6	.44 X .64	13.2	4.8	2.8	5.5
3825-99	5.5	16.5	7.3	17.8	3.6	.44 X .64	13.2	4.8	2.8	5.5
382A-99	5.0	16.5	7.3	17.8	3.6	.44 X .64	13.2	4.8	2.8	5.5
4222 Series	3.5	17.4	8.4	17.6	4.2	.40 X .40	16.1	6.8	4.4	4.9
4223 Series	5.5	17.4	8.4	17.6	4.2	.40 X .40	16.1	6.8	4.4	4.9

(++) HP Class represents market category and is not intended to define actual horsepower Viton® is a registered trademark of E.I. DuPont

(\*) Standard NPT (female) pipe thread.

(\*\*) This dimension may vary due to engine manufacturer's specifications.

NOTE: Dimensions have a tolerance of ±1/8".