



6" Engine Driven Trash Pumps

NEW DIESEL MODEL AVAILABLE

- *Cast Aluminum Casing and Adapter*
- *Cast Iron Seal Plate, Volute & Manifold*
- *Stainless Steel Impeller*
- *Silicon Carbide Mechanical Seal and Buna O-Rings & Flapper/Check Valve*
- *6" NPT Port Size*
- *Self Priming to 20 Ft.*
- *Honda GX670 V-Twin Gas Engine or Daihatsu Vanguard 3/LC Diesel*
- *Available in Trailer Mounted or Skid Mounted*
- *Solids Handling to 3" Diameter*
- *Unique Slide Mechanism Permits Complete Service of Pump Without Removing Hoses or Removing Pump Components From Trailer, PATENT PENDING*
- *Includes Tool Box and Tools for Servicing*
- *12 VDC Electric Start; Digital Tachometer/hourmeter Included*
- *D.O.T. Approved Trailer – See Your State and Local Codes For Registration*

The AMT 6" engine driven pump is designed for applications requiring high volume flow and solid/debris handling capabilities. Pump is constructed of heavy duty sand cast aluminum with cast iron and stainless steel internal parts for wear resistance and durability. Patent pending built-in slide mechanism features nylon and powder coated steel components that permit servicing, repairing and cleaning entire pump without removing hoses or pump components from trailer. Digital tachometer/hourmeter.

AMT Engine Driven Trash pumps are reliable, cost effective and low maintenance. Many are readily available "Off-the-Shelf" for fast 24 hour shipment. For use with non-flammable liquids which are compatible with pump component materials.

Requires 12 Volt Battery; BCI Group 24, Min. of 500 CCA (Cold Crank Amps) Battery Box Cables setup for automotive post type connection.



6" Diesel Driven Trash Pump

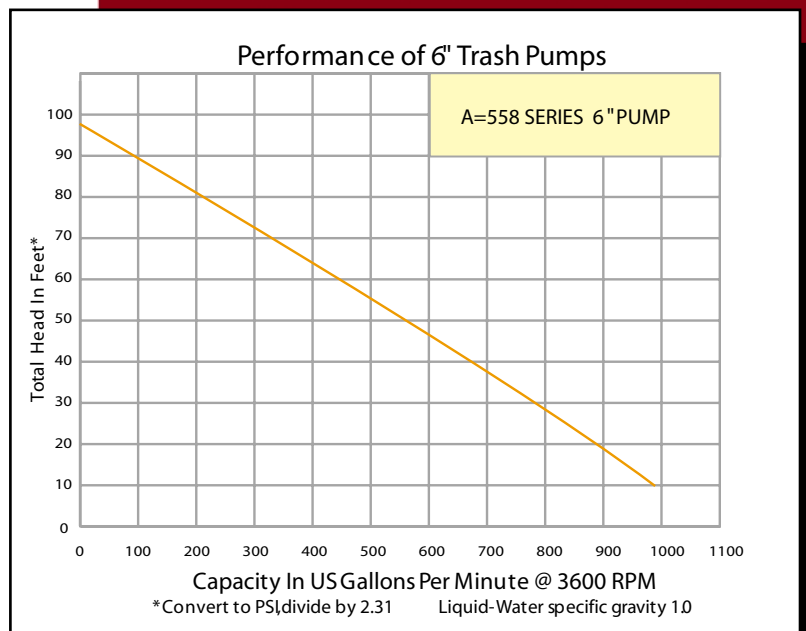

6" Engine Driven Trash Pumps

Pump Dimensional and Specification Data

Model	Curve	Driver	Tank Size	Run Time	Max Solids Dia.	BASE	Ship Wt.	Engine Type
5581-96	A	Honda GX670 V-Twin	12 Gal.	6 Hrs.	3"	Trailer	1000 lbs.	2Cyl. Air Cooled
5582-96	A	Honda GX670 V-Twin	12 Gal.	6 Hrs.	3"	Skid	725 lbs.	2Cyl. Air Cooled
5583-D6	A	Daihatsu Vanguard 3/LC	16 Gal.	9 Hrs.	3"	Trailer	1125 lbs.	3Cyl. Liquid Cooled
5584-D6	A	Daihatsu Vanguard 3/LC	16 Gal.	9 Hrs.	3"	Skid	850 lbs.	3Cyl. Liquid Cooled

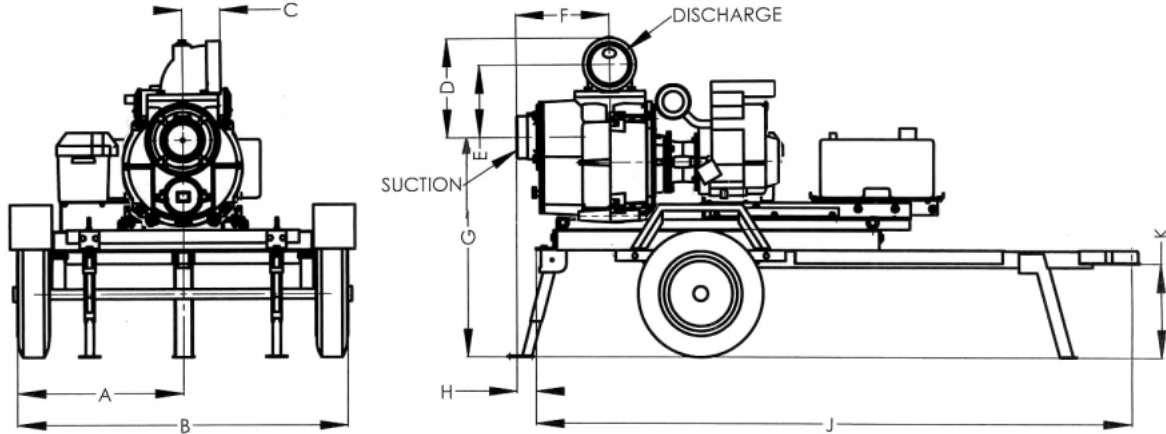

Model	A	B	C	D	E	F	G	H	J	K	Suction	Discharge
5581-96	26	52	5.9	15.2	11.2	14.7	33.2	3	92.3	14.4	6" NPT-M	6" NPT-F
5582-96	19	38	5.9	15.2	11.2	14.7	N/A	N/A	55	N/A	6" NPT-M	6" NPT-F
5583-D6	26	52	5.9	15.2	11.2	14.7	33.2	3	92.3	14.4	6" NPT-M	6" NPT-F
5584-D6	19	38	5.9	15.2	11.2	14.7	N/A	N/A	55	N/A	6" NPT-M	6" NPT-F

Dimensions are in inches and have a tolerance of $\pm 1/8"$

Standard Features

- Cast Aluminum w/Cast Iron and Stainless Steel Parts for Long Lasting Durability
- Silicon Carbide/Viton Mechanical Seal and Buna O-Rings and Fapper/Check Valve
- Built-in Flapper Check Valve for Fast Priming to 20 ft.
- 3" Solids Handling Capability
- Delivers up to 1000 GPM
- Digital Tachometer/hourmeter Installed
- Low Oil Alert
- Available in Trailer Mounted or Skid Mounted
- D.O.T. Approved Trailer – See your state and local codes for registration
- Easy Cleanout and Service Features with the unique AMT Patent Pending Slide Mechanism
- Includes Tool Box with Open End and Hex Wrench Sets for Servicing Pump
- Maximum Temperature 180° F
- 12 VDC Electric Start
- Steel Suction Strainer and Nipple Included